



www.coloradomicrodevices.com

Data Sheet: RadioBlocks CMD-WP1

Colorado Micro Devices, IEEE802.15.4 Wireless Platform

Overview

The CMD-WP1 is an FCC certified IEEE 802.15.4 wireless platform. It is suitable as a plug-in device to add FCC certified wireless capability to an end product or as a stand-alone wireless device. It has been certified for both onboard battery operation or by power derived from the product in which it is mounted. The wireless platform contains an onboard PCB trace antenna and the system exhibits approximately -98dBm sensitivity.

The RF section of the wireless platform is powered by an Atmel AT86RF231 class dominating IEEE 802.15.4 transceiver that is driven by an NXP LPC1114 32-bit Cortex M0 microcontroller. This combination of radio and microcontroller marries the best of the available technologies to provide the best RF performance, power, current consumption, and cost into a 1" (25x25 mm) square FCC certified device.

The device comes with pre-programmed firmware allowing easy setup and deployment of point-to-point or mesh networks. User interface is via standard UART.

Features:

- FCC device certification
- 2.4 GHz IEEE 802.15.4 Atmel radio
- 32-bit Cortex M0 Microcontroller, 32K Flash, 4K SRAM
- Sleep current (with radio sleep and NXP micro in deep-sleep with WDT active) ~4.5uA
- TX Power +3 dBm
- RX sensitivity approximately -98 dBm
- TX current 14mA (at max power)
- RX current 12.3mA
- Onboard power regulated 2.7-5V operation
- Battery power (CR2032) or power from host
- UART (8N1) interface to host (one wire or typical TX/RX interface)
- Simple binary protocol
- I2C interface
- JTAG interface
- One analog channel
- 3+ digital GPIO

Table of Contents

1. INTRODUCTION	3
1.1 WIRELESS PLATFORM INTERFACE	3
1.2 WIRELESS PLATFORM GPIO	3
2. SPECIFICATIONS	4
3. PRODUCT DEVELOPMENT WITH THE CMD-WP1	5
4. FIRMWARE DESCRIPTION	6
5. PIN CONFIGURATION	7
6. ELECTRICAL CHARACTERISTICS	8
A. APPENDIX A ADDITIONAL INFORMATION	9
A.1 ORDERING INFORMATION	9
A.2 APPROVED POWER SUPPLY CONFIGURATION	9
A.3 FCC INTERFERENCE STATEMENT	9
A.4 FCC CAUTIONS	10

1. Introduction

The CMD-WP1 wireless platform enables embedded systems designers to *drop-in* an IEEE802.15.4 wireless component and immediately get down to the business of building their product rather than expending countless hours on RF related issues. Since the device is already FCC certified the designer need not worry about the details of compliance to FCC requirements. Just drop in the wireless platform, work out your host application and get to market. Fast.

1.1 Wireless Platform Interface

The primary interface to the embedded designer is through the UART. Typical settings are 115,200 BAUD, 8N1. The onboard firmware will take care of configuring and initializing the radio. The firmware is already set up to accept data over the UART for transmission via the radio and to transfer received data over the UART to the host processor. Setup your UART for either polling or interrupt on data and the device will effortlessly deliver received frames to your host processor. Alternatively, load your UART with data to transmit and the CMD-WP1 will seamlessly transmit it over the air.

1.2 Wireless Platform GPIO

There are several GPIO available to the embedded designer. Figure 1 shows the major I/O. If the goal is to add a simple sensor directly to the device it can be accomplished through the peripheral I/O.

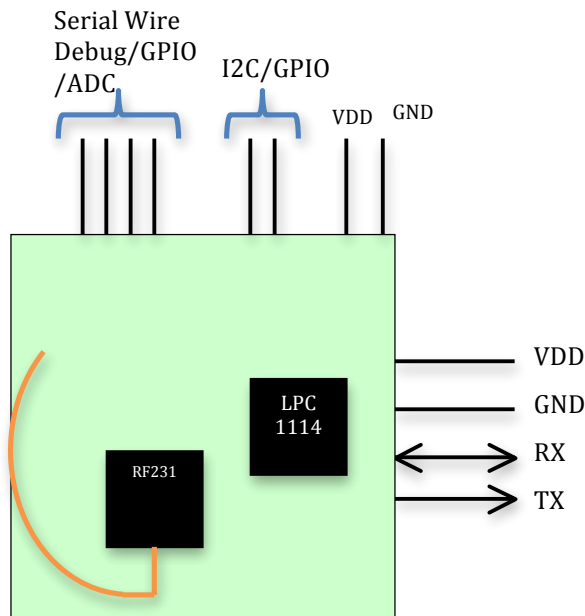

Figure 1 - Wireless Platform Diagram

2. Specifications

RF specifications are based on the Atmel AT86RF231 radio with adjustments made for the onboard PCB trace antenna system. DC characteristics are derived from both the Atmel radio and NXP (LPC1114) data sheets. Values in table are for VDD=3V, at 25 °C, with the micro utilizing its internal RC oscillator running at 12MHz.

Typical DC Characteristics	Value	Comments
Deep sleep current	4.5uA	With active WDT
Wireless Platform TX current	15mA	At +3 dBm - micro in sleep mode
Wireless Platform RX current	13.3mA	micro in sleep
Typical RF Characteristics	Value	Comments
Receive sensitivity	~(-98 dBm)	PER test described in IEEE802.15.4 section 6.5.3.3 (note 1) <i>Actual receive sensitivity can only be inferred from e.i.r.p. and published radio sensitivity.</i>
Radio TX power	+3 dBm	
Peripherals	Comments	
UART	See NXP LPC111x User manual (UM10398.pdf) See CMD-WP1 UART Binary protocol document	
I2C	See NXP LPC111x User manual (UM10398.pdf) Dual use as standard GPIO	
ADC	See NXP LPC111x User manual (UM10398.pdf) Dual use as standard GPIO	
GPIO	See NXP LPC111x User manual (UM10398.pdf)	
Serial Debug Wire	See NXP LPC111x User manual (UM10398.pdf)	

Table 1 - Specifications

3. Product Development with the CMD-WP1

For most applications the wireless platform will provide all the wireless protocol services transparently to the end user. The host micro connected via UART can command the device to enter certain networking modes. The primary networking mode is mesh. All nodes contain the same code so there is no required PAN Coordinator or end node type and all nodes can route. A point-to-point implementation is just a special case of mesh. All nodes require network configuration which is accomplished using the *Network Configuration* GUI program. To maximize usefulness and simplicity while avoiding uselessness, the network requires configuration. The following four items are entered into each node through the GUI:

1. Short (16 bit) address
2. PANID (like an SSID) 16 bit value
3. Channel
4. Network key

Through entering these data the network is commissioned and can be started and will operate automatically. Though the initial channel is required, it may change dynamically during operation as RF conditions change.

With FCC device certification in compliance with CFR 47 FCC part 15, the small size (1 inch square), onboard power regulation, integrated PCB trace antenna and network stack, an end user can insert this wireless platform into their end product without re-testing as an intentional radiator. Thus the user can concentrate on the engineering work that is his product rather than on wireless transport protocols and FCC issues. The essence of the device is to allow the user to drop it into his product, get to market fast, and generate revenue quickly. All that is required of the end user is to be able to configure the UART on his host processor and construct the binary UART protocol described at the web site mentioned earlier.

With respect to FCC certification, the device is approved for both battery operation and deriving power from an off board power supply (i.e. your host board).

4. Firmware Description

The wireless platform is shipped with onboard firmware enabling two basic types of network scenarios: point-to-point and a simple mesh. Check the web site at www.coloradomicrodevices.com/software/documents/ for the latest firmware description and complete documentation.

In addition to the networking modes described above there is a sniffer package available that can be loaded and that works with the CMD USB2UART interface board, a simple Python based GUI program, and Wireshark. More information can be found on the web site.

5. Pin Configuration

The four main connection points are arranged at the bottom of the board in a row labeled J2 with through holes spaced 100 mils apart. Pin 1 is Vdd, Pin 2 is GND, Pin 3 is RXD and Pin 4 is TXD. Note that Pin 3 can also be used for single wire UART connectivity.

There are also two rows of 50 mil spaced through holes for GPIO and dual use Single Wire JTAG debugging and loading; labeled as J1 and J3. The arrangement of J1 is as follows: Pin 1 ISPMODE/PIO0_1, Pin 2 Vdd, Pin 3 SWDIO/PIO1_3/AD4, Pin 4 SWCLK/PIO0_10, Pin 5 RESET/PIO0_0, and Pin 6 GND. The arrangement of J3 is as follows: Pin 1 Battery, Pin 2 Vdd, Pin 3 Power reg, Pin 4 GND, Pin 5 SDA/PIO0_5, and Pin 6 SCL PIO0_4.

The physical layout is shown in figure 2.

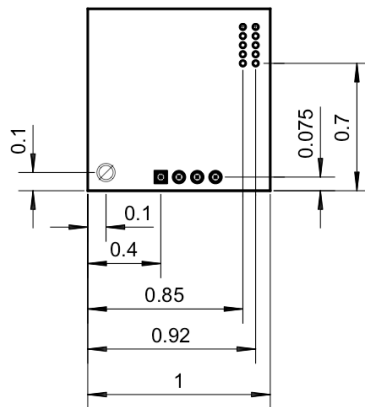

Figure 2 - Pin Locations

Power is supplied to the board through the on board coin cell battery or through off board power applied to pin J2-1. Off board power can be in the range of 3V to 6V and is regulated by the on-board power regulator. The power supply can be selected by jumping pins on J3 as follows:

- Battery power: J3-1 + J3-2
- Off board power: J3-2 + J3-3

Power and GND can be supplied to a sensor board attached via pins J1-2 and J1-6 respectively. CMD provides example code which demonstrates how to integrate sensor boards. While this option is made available to advanced users it will require co-mingling the radio and networking firmware with user code to drive the sensor board if the onboard drivers do not support the sensor interface. The primary interface for sensor boards is via the UART. In other words, the user is encouraged to implement sensor code on their host processor board and package data for sending through the UART and subsequently over the air

6. Electrical Characteristics

For complete electrical reference please examine the datasheets for both the AT86RF231 and the LPC1114.

Parameter	Min	Max
Device supply voltage (VDD) at pin J2-1	2V	6V
Ambient temperature range	-40°C	+85°C
Output VDD at pins J1-2 and J3-2	3.3V	
Output current at pins J1-2 and j3-2	0mA	150mA

Table 2 - Electrical and operational characteristics

A. Appendix A Additional Information

A.1 Ordering Information

- RBB (RadioBlock Battery Powered)
- RBM (RadioBlock Mains Powered)

Label line 1: FCC ID:

Label line 2: Z2D-1



Figure 3 – Example - wireless platform labeling for FCC approved device

A.2 Approved Power Supply configuration

The CMD-WP1 has received FCC device approval for both battery and mains power operation.

A.3 FCC Interference Statement

FCC-B Radio Frequency Interference Statement

This equipment has been tested and found to comply with the limits for a Class B digital device, pursuant to Part 15 of the FCC Rules. These limits are designed to provide reasonable protection against harmful interference in a residential installation. This equipment generates, uses, and can radiate radio frequency energy. If not installed and used in accordance with the instructions, this may cause harmful interference to radio communications. However, there is no guarantee that interference will not occur in a particular installation. If this equipment does cause harmful interference to radio or television reception, which can be determined by turning the equipment off and on, the user is encouraged to try to correct the interference by one or more of the measures listed below.

- Reorient or relocate the receiving antenna.
- Increase the separation between the equipment and receiver.
- Connect the equipment into an outlet on a circuit different from that to which the receiver is connected.
- Consult the dealer or an experienced radio/television technician for help.

This device complies with Part 15 of the FCC Rules. Operation is subject to the following two conditions:

1. This device may not cause harmful interference, and
2. This device must accept any interference received, including interference that may cause undesired operation



A.4 FCC Cautions

FCC Caution: Any changes or modifications not expressly approved by the party responsible for compliance could void the user's authority to operate this equipment.

The transmitter device must not be co-located with any other antenna or transmitter.